



**FITTING INSTRUCTIONS FOR LP0386BK**



**LICENCE PLATE BRACKET**

**This kit contains the items pictured and labelled over page.**

**Some parts may be shown for clarity of instructions only.**

**Do not proceed until you are sure all parts are present.**

**Please read all instructions before proceeding.**

**IF IN ANY DOUBT WHEN FITTING OUR PRODUCTS, CONSULT ONE OF OUR DEALERS  
OR HAVE FITTED BY A QUALIFIED TECHNICIAN.**

Please note that the way the kit is packed does not necessarily represent the way of mounting to the bike.

In the event of rubber washers being used to hold components onto bolts, these rubber washers can be thrown away.

R&G

Unit 1, Shelley's Lane, East Worldham, Alton, Hampshire, GU34 3AQ  
Tel: +44 (0)1420 89007 [www.rg-racing.com](http://www.rg-racing.com) Email: [info@rg-racing.com](mailto:info@rg-racing.com)



<b><u>TOOLS REQUIRED</u></b>	<b><u>GENERAL TORQUE SETTINGS</u></b>
<ul style="list-style-type: none"> <li>• Set of metric Hex keys to include 5mm &amp; 6mm.</li> <li>• Set of metric sockets and wrench. To include 8mm, 10mm &amp; 12mm.               <ul style="list-style-type: none"> <li>• Cable cutters</li> </ul> </li> </ul>	<p>M4 BOLT = 8Nm</p> <p>M5 BOLT = 12Nm</p> <p>M6 BOLT = 15Nm</p> <p>M8 BOLT = 20Nm</p> <p>M10 BOLT = 40Nm</p> <p>M12 BOLT = 40Nm</p>

### **LEGEND**

<b>ITEM No.</b>	<b>DESCRIPTION</b>	<b>QTY</b>
ITEM 1	MAIN BRACKET	1
ITEM 2	NUMBER PLATE BRACKET	1
ITEM 3	COVER PLATE	1
ITEM 4	COUNTERSUNK BOLT	4
ITEM 5	COUNTERSUNK BOLT	3
ITEM 6	NYLOC NUT	7
ITEM 7	FLAT WASHER	7
ITEM 8	INDICATOR SPACER	2
ITEM 10	LICENSE PLATE LIGHT INC SHROUD	1

R&G

Unit 1, Shelley's Lane, East Worldham, Alton, Hampshire, GU34 3AQ  
 Tel: +44 (0)1420 89007 [www.rg-racing.com](http://www.rg-racing.com) Email: [info@rg-racing.com](mailto:info@rg-racing.com)



**FITTING PICTURES**

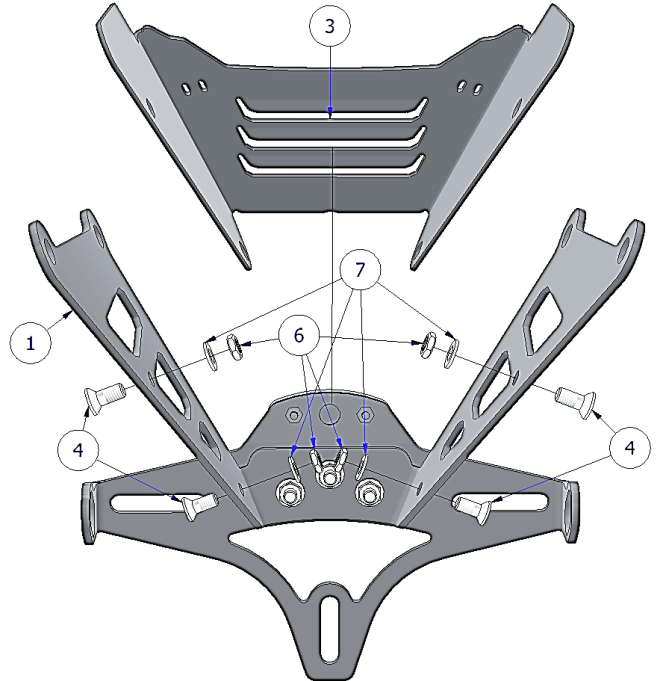
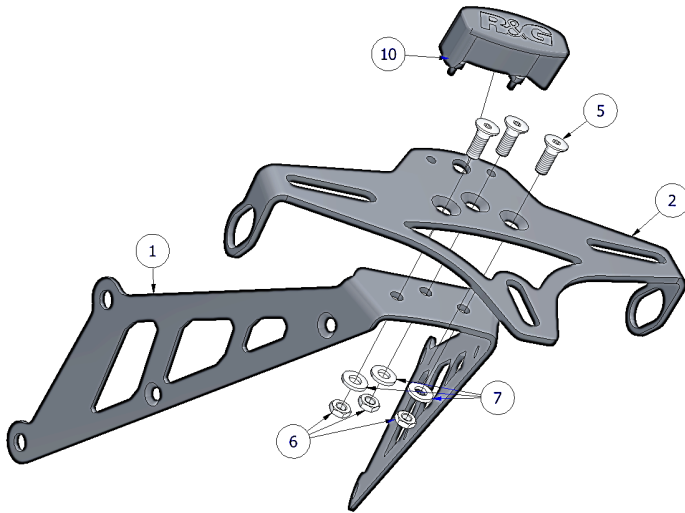

**PICTURE 1**

**PICTURE 2**

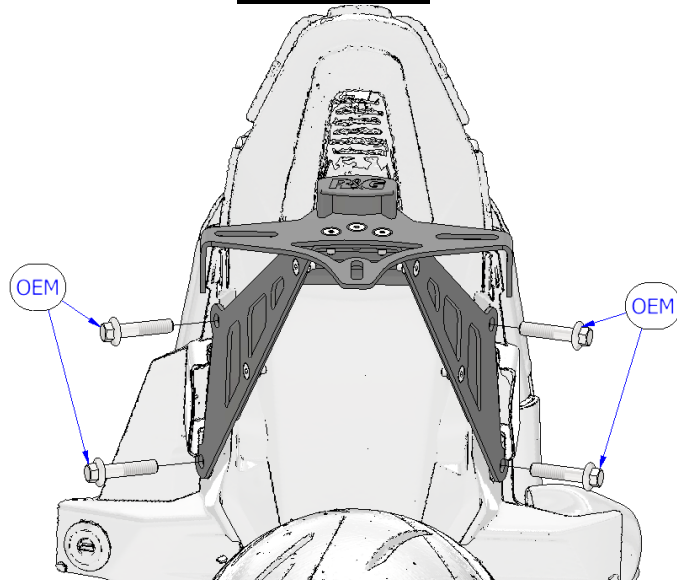
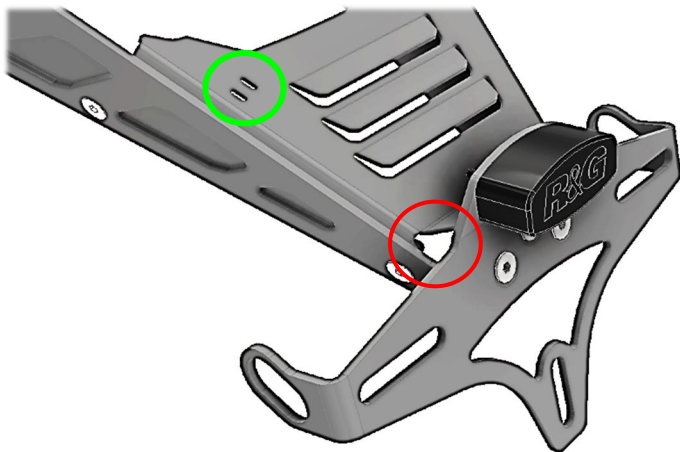

**PICTURE 3**

**PICTURE 4**



## **FITTING INSTRUCTIONS**

### **Disassembly of OEM Tail Unit:**

- Disconnect the wiring connectors going to the OEM Tail Unit located under the passenger seat.
- Remove the OEM rear fairings and tail unit via the four bolts underneath the fairings.
- Un-screw all visible bolts on the OEM Tail Unit then remove the OEM indicators for later use.
- Re-assemble the OEM Tail unit without the indicators and store away safely.

### **Tail Tidy Assembly:**

- Firstly, apply heat shrink to the number plate light wiring and also the indicator wiring if required.
- Attach the number plate light (**Item 10**) & OEM indicators to the number plate bracket. Using the supplied nuts, washers & indicator spacers (**Item 8**).
- Then attach the assembly to the main mounting bracket (**Item 1**), using the washers & nyloc nuts (**Items 6 & 7**) (See **Picture 1**)
- Once the light units have been attached, attach the cover plate (**Item 3**) using the supplied countersunk bolts, washers and nyloc nuts (**Items 4, 7 & 6**) (See **Picture 2**)

#### ***Please note:***

*The indicator wiring should be passed through the gap highlighted in red in **Picture 3** and the number plate light should be between the slot cut into the front of the cover plate.*

- Using the supplied cable ties fasten the wiring to the cover plate using the slots highlighted in green, making sure the head of the cable tie is on the underside of the cover plate.
- Pass the wiring through the hole in the motorcycle's undertray, loosely fit the 4X OEM mounting bolts to keep it in position. (See **Picture 4**)
- Test the indicators and number plate light to make sure they work correctly before finally tightening all four mounting bolts to the OEM torque spec.
- Re-assemble the tail unit.

**IMPORTANT: FOR SAFETY, ENSURE THE LICENCE PLATE IS PLACED AS HIGH AS POSSIBLE ON THE TAIL TIDY (IT MAY REQUIRE DRILLING). IF FITTING A LICENCE PLATE OF 200MM OR LONGER (INCLUDING ANY SHROUD OR REFLECTOR ATTACHMENT) TO THE BRACKET, BEFORE RIDING, FULLY COMPRESS THE SUSPENSION TO ENSURE NO PART OF THE ASSEMBLY CAN CONTACT THE TYRE WHILE THE VEHICLE IS IN MOTION OR UNDER LOAD. IT IS YOUR RESPONSIBILITY TO CHECK FOR THIS POSSIBILITY AND TAKE AVOIDING ACTION. FAILURE TO CHECK THIS COULD RESULT IN SERIOUS INJURY OR DAMAGE TO THE MOTORCYCLE.**

ISSUE 1 - 16/10/2024 (TB)

R&G

Unit 1, Shelley's Lane, East Worldham, Alton, Hampshire, GU34 3AQ  
Tel: +44 (0)1420 89007 [www.rg-racing.com](http://www.rg-racing.com) Email: [info@rg-racing.com](mailto:info@rg-racing.com)

**CONSUMER NOTICE**

The catalogue description and any exhibition of samples are only broad indications of the Products and R&G may make design changes which do not diminish their performance or visual appeal and supplying them in such state shall conform to the order. The Buyer acknowledges no representation or warranty (other than as to title) has been given or will apply to the Products other than those in R&G's order or confirmation and the Buyer confirms it has chosen the Products as being of merchantable quality and suitable for its particular purposes. Where R&G fits the Products or undertakes other services it shall exercise reasonable skill and care and rectify any fault free of charge unless the workmanship has been disturbed. The Buyer is responsible for ensuring that the warranty on the motorcycle is not affected by the fitting of the Products. On return of any defective Products R&G shall at its option either supply a replacement or refund the purchase money but shall not be liable if the Products have been modified or used or maintained otherwise than in accordance with R&G's or manufacturer's instructions and good engineering practice or if the defect arises from accident or neglect. Other than identified above and subject to R&G not limiting its liability for causing death and personal injury, it shall not be liable for indirect or consequential loss and otherwise its liability shall be limited to the amounts paid by the Buyer for the Products or the fitting or service concerned. These terms do not affect the Buyer's statutory rights.

**R&G RACING RETURNS POLICY (NON-FAULTY GOODS)**

Returns must be pre-authorized (if not pre-authorized the return will be rejected). Goods may only be returned direct to us if they were purchased direct from us (customer must prove if necessary). Otherwise to be returned to original vendor. Goods must be in re-sellable condition, in the opinion of R&G Racing. All returns are subject to a 25% restocking and handling fee (25% of the gross value exc. P&P - at the prevailing price at time of purchase). The customer must pay any and all carriage charges. No returns of discontinued products, unless within 14 days of purchase. This policy does not affect your statutory rights and does not refer to faulty goods.

R&amp;G

Unit 1, Shelley's Lane, East Worldham, Alton, Hampshire, GU34 3AQ  
Tel: +44 (0)1420 89007 [www.rg-racing.com](http://www.rg-racing.com) Email: [info@rg-racing.com](mailto:info@rg-racing.com)