



FITTING INSTRUCTIONS FOR CR0092BK COTTON REELS



THIS KIT CONTAINS THE ITEMS PICTURED AND LABELLED OVER PAGE.

SOME PARTS MAY BE SHOWN FOR CLARITY OF INSTRUCTIONS ONLY.

DO NOT PROCEED UNTIL YOU ARE SURE ALL PARTS ARE PRESENT.

PLEASE READ ALL INSTRUCTIONS BEFORE PROCEEDING.

IF IN ANY DOUBT WHEN FITTING OUR PRODUCTS, CONSULT ONE OF OUR DEALERS OR HAVE FITTED BY A QUALIFIED TECHNICIAN.

PLEASE NOTE THAT THE WAY THE KIT IS PACKED DOES NOT NECESSARILY REPRESENT THE WAY OF MOUNTING TO THE BIKE.

IN THE EVENT OF RUBBER WASHERS BEING USED TO HOLD COMPONENTS ONTO BOLTS, THESE RUBBER WASHERS CAN BE THROWN AWAY.



| <u>TOOLS REQUIRED</u> | <u>GENERAL TORQUE SETTINGS</u> |
|---|---|
| <ul style="list-style-type: none"> Set of Metric Allen Keys. | M4 BOLT = 8Nm M5 BOLT = 12Nm M6 BOLT = 15Nm M8 BOLT = 20Nm M10 BOLT = 40Nm M12 BOLT = 40Nm |

LEGEND

| ITEM NO. | DESCRIPTION | QTY |
|-----------------|--|------------|
| ITEM 1 | MOUNTING BLOCK | 2 |
| ITEM 2 | LHS BLANKING SPACER | 1 |
| ITEM 3 | BOBBIN | 2 |
| ITEM 4 | BOBBIN SPACERS | 2 |
| ITEM 5 | M8x50mm CAP HEAD BOLT - BOBBINS | 2 |
| ITEM 6 | M6x10mm - CAP HEAD BOLT - CHAIN ADJUSTER STOPPER | 2 |
| ITEM 7 | 14mm WASHER | 2 |
| ITEM 8 | BOLT CAP | 2 |

COMPONENT PARTS DIAGRAM

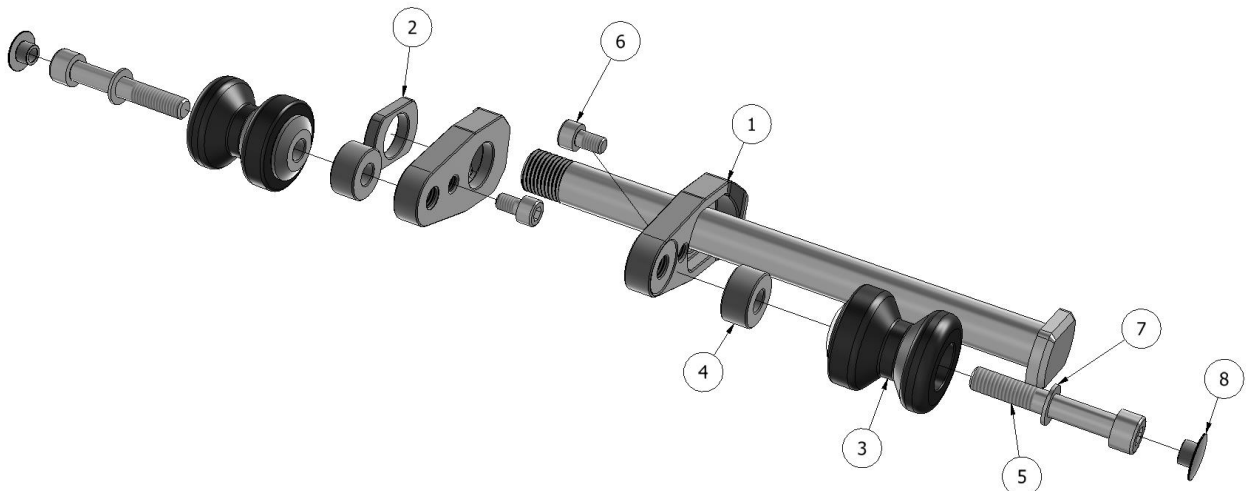



FITTING INSTRUCTIONS

- Remove the rear axle nut, washer and OEM chain adjuster block, then gently tap the rear axle out with a mallet.
- Once the axle is removed, remove the other OEM chain adjuster block.
- Insert both 10mm M6 bolt (**Item 6**) into the flat side of the R&G adjuster blocks.
- Slide one of the R&G chain adjuster blocks (**Part 1**) over the axle and locate the flat oval shaped end of the axle into the corresponding female oval cut out in the adjuster block. (As shown in the Diagram above)
- Slide the axle back through the swingarm, wheel and any spacers that were in place.
- Once through to the other side of the swingarm, place the remaining R&G chain adjuster block over the axle, followed by the spacer (**Item 2**), then the OEM washer and axle nut.
- Check the chain tension and wheel alignment before torquing the axle to its required spec.
- Pass the remaining M8 bolts through their washers (**Item 7**), then through the bobbins (**Item 3**) and spacers (**Item 4**) and thread into the mounting blocks.
- Once the bobbins have been torqued, apply the bolt caps (**Item 8**) to the heads of the M8 bolts.

ISSUE 1 – 15/8/2024 (TB)

CONSUMER NOTICE

The catalogue description and any exhibition of samples are only broad indications of the Products and R&G may make design changes which do not diminish their performance or visual appeal and supplying them in such state shall conform to the order. The Buyer acknowledges no representation or warranty (other than as to title) has been given or will apply to the Products other than those in R&G's order or confirmation and the Buyer confirms it has chosen the Products as being of merchantable quality and suitable for its particular purposes. Where R&G fits the Products or undertakes other services it shall exercise reasonable skill and care and rectify any fault free of charge unless the workmanship has been disturbed. The Buyer is responsible for ensuring that the warranty on the motorcycle is not affected by the fitting of the Products. On return of any defective Products R&G shall at its option either supply a replacement or refund the purchase money but shall not be liable if the Products have been modified or used or maintained otherwise than in accordance with R&G's or manufacturer's instructions and good engineering practice or if the defect arises from accident or neglect. Other than identified above and subject to R&G not limiting its liability for causing death and personal injury, it shall not be liable for indirect or consequential loss and otherwise its liability shall be limited to the amounts paid by the Buyer for the Products or the fitting or service concerned. These terms do not affect the Buyer's statutory rights.

R&G RETURNS POLICY (NON-FAULTY GOODS)

Returns must be pre-authorized (if not pre-authorized the return will be rejected). Goods may only be returned direct to us if they were purchased direct from us (customer must prove if necessary). Otherwise to be returned to original vendor. Goods must be in re-sellable condition, in the opinion of R&G. All returns are

R&G

Unit 1, Shelley's Lane, East Worldham, Alton, Hampshire, GU34 3AQ

Tel: +44 (0)1420 89007 Email: info@rg-racing.com