



### KAOKO™ THROTTLE STABILIZER KITS: SUZ115

RSA Registered Designs  
No. A2007/00202 No. A2007/00205  
No. A2007/00203 No. A2007/00206  
No. A2007/00204 No. A2007/00207

Patents  
"U.S. Pat. No. US D593,462 S"  
"U.S. Pat. No. US D593,463 S"  
"U.S. Pat. No. US D593,464 S"

For Models SUZUKI  
GSXR-1000 (2017-2021)

**Items Included in your kit**  
Kaoko bar-end body • Friction Nut • 100 Thrust washer • 2mm Allen Key  
Fitting Instructions

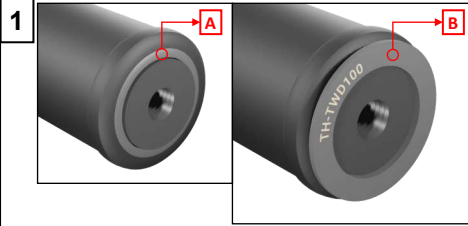

- A**—Plastic throttle sleeve
- B**—100 Thrust washer

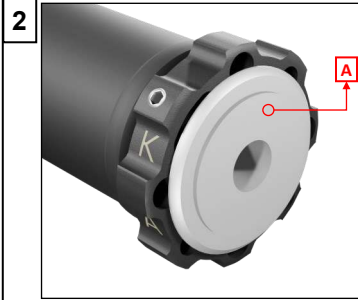

- A**—Kaoko bar-end body

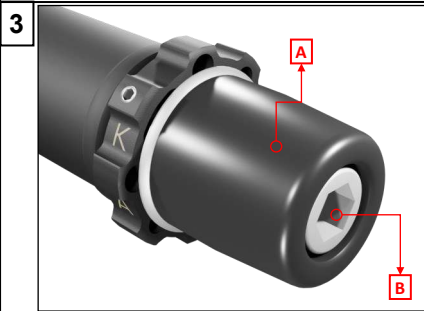

- A**—OEM bar-end weight
- B**—OEM screw

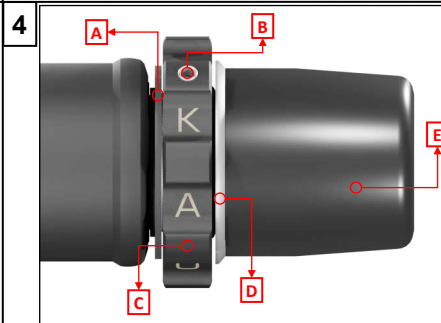

- A**—100 Thrust Washer
- B**—Grub screw
- C**—Friction nut
- D**—Kaoko bar-end body
- E**—OEM bar-end weight

**DISCLAIMER: NO RESPONSIBILITY ACCEPTED FOR NON-ADHERENCE TO THESE INSTRUCTIONS**

#### KAOKO™ Safety Warning:

The KAOKO™ Throttle Stabilizer is an aftermarket accessory. Any misunderstood, abused or incorrectly installed motorcycle accessory is a safety hazard that could cause injury or death. It's the rider's responsibility to understand the operation and purpose for which the KAOKO™ Throttle Stabilizer is designed, namely, for cruising, only when safe to do so. At all other times the control should be disengaged. The KAOKO™ Throttle Stabilizers are to be used only by experienced and responsible riders. See reverse of page for full indemnity.

**Note:** An adjustment to throttle assembly position may be necessary to suit KAOKO™ Throttle Stabilizers. The throttle assembly position on aftermarket bars, and some OEM bars, is adjustable. The assembly can marginally be re-positioned along the handle bars slightly loosening the throttle assembly clamp screws, and then sliding the throttle assembly along the handle bars (left or right). Once done, firmly tighten the clamp screws to OEM torque specifications. This adjustment is generally not necessary.

### Fitting Instructions

#### Step 1

Completely remove the OEM right hand side bar weight to expose the handlebar and *plastic throttle sleeve* as shown in **picture 1**.

#### Step 2

Place the *100 thrust washer* onto end the of the throttle sleeve making sure that the *spigot* of the thrust washer makes contact with the *plastic throttle sleeve* as shown in **picture 1**.

**Note:** To enable improved functionality, it is recommended (not essential) to apply very light smear of Automotive grease or Petroleum jelly to the friction face of the thrust washer( See Figure 3 at the back of the page)

#### Step 3

Place the KAOKO™ bar-end body onto the end of the handlebar and make sure that it fully nests onto the end of the handlebar as shown in **picture 2**.

#### Step 4

Place the OEM bar-end weight over the Kaoko bar-end body and using your OEM screw, fasten the KAOKO™ Throttle Stabilizer kit with the OEM bar-end weight as shown in **picture 3**. It is recommended to use a mild thread locking adhesive.

**Note:** Make sure to turn the friction nut so that there is a **1.5mm—2mm gap** between the friction nut and the shoulder of the Kaoko bar-end body prior to tightening the full assembly, see **figure 3** on the back of the page for more information.

#### Step 5

Carefully set the rotational resistance of the friction nut by tightening/loosening the *grub screw* (as shown in **picture 4**) by small adjustments using the 2mm allen key provided in the Kaoko Kit.

Take care not to over tighten risking damage to threads. The nut should have fairly firm rotational resistance. See under **Maintenance below**.

### Operating Instructions

The Friction Nut has a **left hand thread**. In readiness for engagement, the Friction Nut must be adjusted so that it makes light contact against the thrust washer.

**To Engage:** While rolling on the throttle, the Friction Nut can be gripped between the small finger and palm of hand. This action tightens the nut and provides sufficient friction to set the throttle to the desired opening. (The friction is such that the rider may still open and close the throttle. The throttle simply has a slight rotational stiffness.)

**To Disengage:** While rolling off the throttle, grip the Friction Nut between small finger and palm of hand.

**VERY IMPORTANT!!** The throttle should open and snap closed freely when correctly disengaged.

**Note:** The Grub Screw needs to be set to provide the necessary resistance on the thread of the friction nut (only small adjustments need to be made as to not damage the friction nut threads). This may be adjusted periodically to take up wear.

**Maintenance:** Remove kit annually. Unscrew Friction Nut and brush clean threads with a mild soap. Apply petroleum jelly to threads and assemble. Adjust grub screw to desired operating resistance. (O-Ring cushion: 19.6mm I.D. x 2.4mm section — if replacement is required)