



FITTING INSTRUCTIONS FOR CG0015BK CHAIN GUARD
TRIUMPH BONNEVILLE BOBBER '17-



THIS KIT CONTAINS THE ITEMS PICTURED AND LABELLED BELOW.
DO NOT PROCEED UNTIL YOU ARE SURE ALL PARTS ARE PRESENT.

Please note that the way the kit is packed does not necessarily represent the way of mounting to the bike.

THE PARTS SHOWN MAY BE REPRESENTATIVE ONLY (FOR CLARITY OF INSTRUCTIONS ONLY).

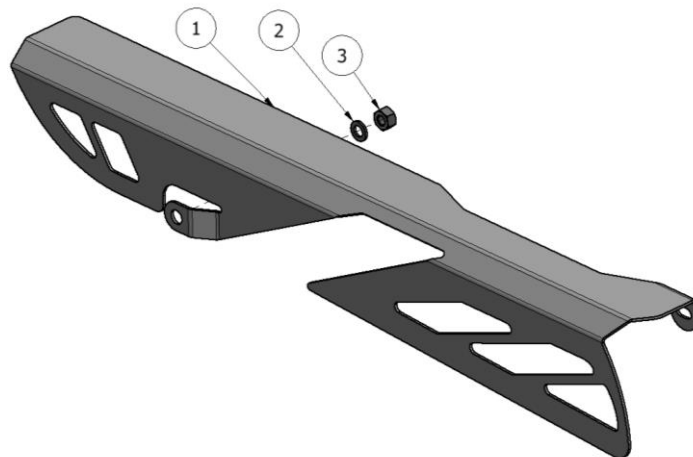

LEGEND

ITEM 1 = CHAIN GUARD (SMW0106) (x1)

ITEM 2 = M8 WASHER (x1)

ITEM 3 = M8 NYLOC NUT (x1)



Please note that in cases where kits are packed with rubber washers holding the components onto the bolt – *the rubber washers should be thrown away!*

TOOLS REQUIRED

- Set of torx drivers.
- Set of metric spanners.

MAXIMUM TORQUE SETTINGS

- M4 Bolt = 8 Nm
- M5 Bolt = 12 Nm
- M6 Bolt = 15 Nm
- M8 Bolt = 20 Nm



Picture 1



Picture 2



Picture 3



Picture 4



FITTING INSTRUCTIONS

- To fit the R&G chain guard remove the 2 torx bolts arrowed in pictures 1 and 2.
- Remove the OEM chain guard.
- Fit the R&G chain guard (item 1) into position the same way the OEM chain guard was removed.
- Using the OEM bolt removed in picture 1 and the supplied M8 washer (item 2) and M8 nyloc nut (item 3) secure the rear mount of the guard loosely in place.
- Use the OEM torx bolt to secure the front chain guard mount in place and then tighten the rear mount.

ISSUE 1 01/02/2018 (HB)

Digital copies of these instructions are available to download from www.rg-racing.com

CONSUMER NOTICE

The catalogue description and any exhibition of samples are only broad indications of the Products and R&G may make design changes which do not diminish their performance or visual appeal and supplying them in such state shall conform to the order. The Buyer acknowledges no representation or warranty (other than as to title) has been given or will apply to the Products other than those in R&G's order or confirmation and the Buyer confirms it has chosen the Products as being of merchantable quality and suitable for its particular purposes. Where R&G fits the Products or undertakes other services it shall exercise reasonable skill and care and rectify any fault free of charge unless the workmanship has been disturbed. The Buyer is responsible for ensuring that the warranty on the motorcycle is not affected by the fitting of the Products. On return of any defective Products R&G shall at its option either supply a replacement or refund the purchase money but shall not be liable if the Products have been modified or used or maintained otherwise than in accordance with R&G's or manufacturer's instructions and good engineering practice or if the defect arises from accident or neglect. Other than identified above and subject to R&G not limiting its liability for causing death and personal injury, it shall not be liable for indirect or consequential loss and otherwise its liability shall be limited to the amounts paid by the Buyer for the Products or the fitting or service concerned. These terms do not affect the Buyer's statutory rights.

R&G RETURNS POLICY (NON-FAULTY GOODS)

Returns must be pre-authorised (if not pre-authorised the return will be rejected). Goods may only be returned direct to us if they were purchased direct from us (customer must prove if necessary). Otherwise to be returned to original vendor. Goods must be in re-sellable condition, in the opinion of R&G. All returns are subject to a 25% restocking and handling fee (25% of the gross value exc. P&P – at the prevailing price at time of purchase). The customer must pay any and all carriage charges. No returns of discontinued products, unless within 14 days of purchase. This policy does not affect your statutory rights and does not refer to faulty goods.

R&G

Unit 1, Shelley's Lane, East Worldham, Alton, Hampshire, GU34 3AQ
Tel: +44 (0)1420 89007 Fax: +44 (0)1420 87301 www.rg-racing.com Email: info@rg-racing.com